

SRT-94

- ▣ temperature meter with a large display
- ▣ input: thermoresistance or thermocouple
- ▣ 0, 2 or 4 relay outputs (or OC)
- ▣ RS-485 / Modbus RTU
- ▣ option: active current output



The **SRT-94** temperature meter has one input: thermoresistance (Pt100/500/1000) or thermocouple (K, S, J, T, N, R, B, E). Measurement is linearised by the polynomial characteristics. The device with thermocouple input has additional measurement range (-10 ÷ 90 mV) mainly for diagnostics of measurement circuits. A 4-digits, 20-millimetre LED display enables seeing of measured values from a distance. The RS-485 enables data transmission in production process monitoring systems. 2 or 4 relay (or OC) outputs make it possible to adjust the level of the measured signal. Every relay output can be controlled according to one or two threshold values.

- programmable hystereses and delays of control outputs,
- programmable indication filtration,
- automatic recognition of 3 and 4-conductor connection (Pt inputs),
- automatic compensation of TC cold ends temperature,
- signal peak value detection,
- alarm diode and acoustic signal in case of sensor damage.

Exemplary pin assignment

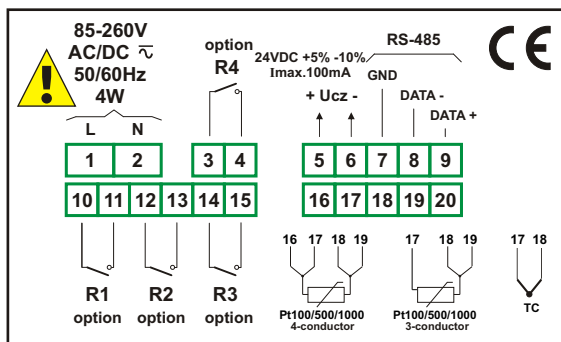

version without 4-20 mA output

Ordering

SRT-94-1XXX-1-X-XX1

options:

- 00 : no options
- 01 : IP 65 frame

power supply:

- 3 : 24V AC/DC
- 4 : 85V - 260V AC/DC

type of outputs:

- 0 : no output
- 1 : REL (for 2 and 4 outputs)
- 2 : OC (for 2 and 4 outputs)
- 3 : 2 x REL + current output
- 4 : 2 x OC + current output

type of input:

- 3 : thermoresistance
- A : thermocouple

- 0
- 2
- 3
- 4

Typical applications

1. Temperature regulation in refrigeration plants (in co-operation with Pt100 sensor) with operation of refrigerating units according to preset parameters.

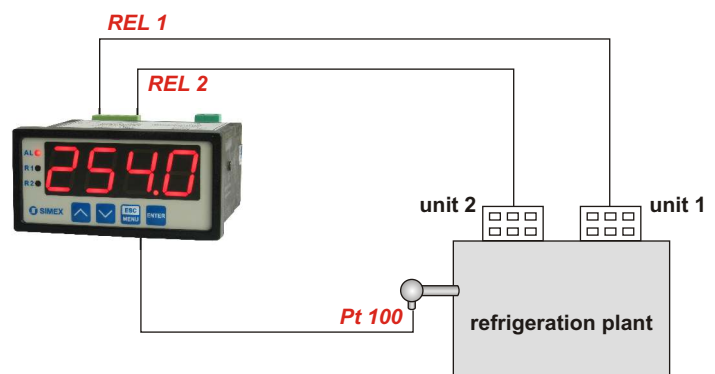

Technical data

Power supply: 19V + 50V DC; 16V + 35V AC or 85 + 260V AC/DC, all separated

Power consumption: for 85 + 260V AC/DC and 16V + 35V AC power supply: max. 4,5 VA; 19V + 50V DC power supply: max. 4,5 W

Display: LED, 4 x 20 mm high, red (green - on request)

Input:

thermoresistance: Pt100, Pt500, Pt1000 (automatic recognition of 3 and 4-conductor connection, resistance compensation of connecting conductors from 0 to 20 Ω at any conductor); measuring range: -100°C + 600°C; resolution: 0,1°C

thermocouple: type K, S, J, T, N, R, B, E; measuring range: **K:** -200°C + +1370°C;

S: -50°C + +1768°C; **J:** -210°C + +1200°C; **T:** -200°C + +400°C;

N: -200°C + +1300°C; **R:** -50°C + +1768°C; **B:** +250°C + +1820°C;

E: -200°C + +1000°C; resolution: 1°C, additional range -10 + +90 mV

Accuracy: 0.1% @25°C

Stability: 50 ppm/°C

Outputs: 0, 2 or 4; relays 1A/250V AC (cosφ=1) or the OC 30mA/30VDC/100mW

Transducer power supply output: 24V DC +5%, -10% / max. 100 mA, stabilized, not insulated from measuring inputs

Active current output: operating range max. 0 - 24 mA, load resistance max. 700 Ω (option available with 2 relays, see ordering)

Communication interface: RS-485, 8N1 and 8N2, 1200 bit/s + 115200 bit/s, Modbus RTU (not galvanically insulated)

Operating temperature: 0°C + +50°C

Storage temperature: -10°C + +70°C

Protection class: IP 65 (front), available additional frame IP 65 for panel cut-out sealing; IP 20 (case and connection clips)

Case: board

Case material: NORYL - GFN2S E1

Case dimensions: 96 x 48 x 100 mm

Panel cut-out dimensions: 90,5 x 43 mm

Installation depth: min. 102 mm

Board thickness: max. 5 mm