

SRT-73

- ▣ temperature meter in a small case
- ▣ input: thermoresistance or thermocouple
- ▣ 0, 1 or 2 relay outputs (or OC type)
- ▣ two-coloured display (standard version)
- ▣ power supply output: 24V DC
- ▣ RS-485 / Modbus RTU



Easy programming and installation, small size and high reliability are basic advantages of the **SRT-73** temperature meters. They have one input: thermoresistance (Pt100/500/1000) or thermocouple (K, S, J, T, N, R, B, E). Measurement is linearised by the polynomial characteristics. The device with thermocouple input has additional measurement range (-10 ÷ 90 mV) mainly for diagnostics of measurement circuits. 1 or 2 relay (or OC) outputs make it possible to control heating / cooling processes. The RS-485 enables data transmission in production process monitoring systems.

- programmable hystereses and delays of control outputs,
- password protected,
- programmable indication filtration,
- versions available with AC and DC power supply,
- automatic recognition of 3 and 4-conductor connection (Pt inputs),
- automatic compensation of TC cold ends temperature,
- alarm diode and acoustic signal in case of sensor damage.

Typical applications

1. Temperature adjustment in greenhouses performed from the central computer via an RS-485 interface; process visualization possible.

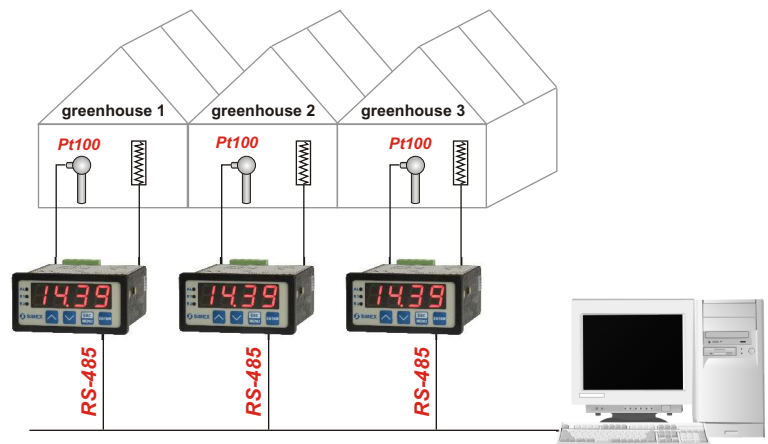

Exemplary pin assignment

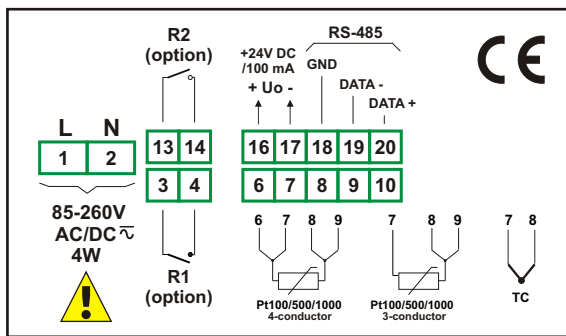

Technical data

Power supply: 19V ÷ 50V DC; 16V ÷ 35V AC or 85 ÷ 260V AC/DC, all separated
Power consumption: for 85 ÷ 260V AC/DC and 16V ÷ 35V AC power supply: max. 4,5 VA; 19V ÷ 50V DC power supply: max. 4,5 W
Display: LED, two-coloured (red-green), 4 x 13 mm (IP 40) - standard or LED, red, 5 x 9 mm (IP 65) - option
Input:
 thermoresistance: Pt100, Pt500, Pt1000 (automatic recognition of 3 and 4-conductor connection, resistance compensation of connecting conductors from 0 to 20 Ω at any conductor); measuring range: -100°C ÷ 600°C; resolution: 0,1°C
 thermocouple: type K, S, J, T, N, R, B, E; measuring range: **K:** -200°C ÷ +1370°C; **S:** -50°C ÷ +1768°C; **J:** -210°C ÷ +1200°C; **T:** -200°C ÷ +400°C; **N:** -200°C ÷ +1300°C; **R:** -50°C ÷ +1768°C; **B:** +250°C ÷ +1820°C; **E:** -200°C ÷ +1000°C; resolution: 1°C, additional range -10 ÷ +90 mV
Accuracy: 0.1% @25°C
Stability: 50 ppm/°C
Outputs: 0, 1 or 2 relays 1A/250V AC (cosφ=1) or OC 30mA/30VDC/100 mW
Transducer power supply output: 24V DC ÷ 5%, -10% / max. 100 mA, stabilized, not insulated from measuring inputs
Communication interface: RS-485, 8N1 and 8N2, 1200 bit/s ÷ 115200 bit/s, Modbus RTU (not galvanically insulated)
Operating temperature: 0°C ÷ +50°C
Storage temperature: -10°C ÷ +70°C
Protection class (depending on display size):
 5 x 9 mm display: IP 65 (front), available additional frame IP 65 for panel cut-out sealing; IP 20 (case and connection clips)
 4 x 13 mm display: IP 40 (front); IP 20 (case and connection clips)
Case: board
Case material: NORYL - GFN2S E1
Case dimensions: 72 x 36 x 97 mm
Panel cut-out dimensions: 66,5 x 32,5 mm
Installation depth: min. 102 mm
Board thickness: max. 5 mm

Ordering

SRT-73-1XXX-1-X-XX1

- options:**
 - 00 : no options
 - 01 : IP 65 frame
- power supply:**
 - 3 : 24V AC/DC
 - 4 : 85V - 260V AC/DC
- type of outputs:**
 - 0 : no output
 - 1 : REL
 - 2 : OC
- number of outputs:**
 - 0
 - 1
 - 2
- type of input:**
 - 3 : thermoresistance
 - A : thermocouple