

SRP-73

- ▣ process meter in a small case
- ▣ input 0/4-20 mA, 0/1-5V, 0/2-10V, 0-60 mV, 0-75 mV, 0-100 mV, 0-150 mV
- ▣ 0, 1 or 2 relay outputs (or OC type)
- ▣ power supply output: 24V DC
- ▣ RS-485 / Modbus RTU



Easy programming and installation, small size and high reliability are basic advantages of the **SRP-73** process meters. 1 or 2 relay outputs (or OC) make it possible to control processes ON/OFF type. The additional advantage is possibility of programming following modes: linear, root, square and user defined (max. 20 points). The additional 24VDC output is used to power the measuring transducers and the RS-485 enables data transmission in production process monitoring systems.

- two-coloured display for IP40 version,
- programmable input kind and measuring range,
- overload-protected current input,
- programmable indication filtration,
- programmable hystereses and delays of control outputs.

Exemplary pin assignment

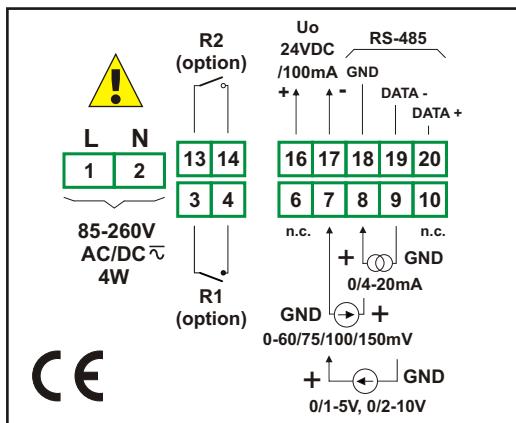

Ordering

SRP-73-1XXX-1-X-XX1

options:
00 : no options
01 : IP 65 frame

power supply:
3 : 24V AC/DC
4 : 85V - 260V AC/DC

type of input:
8 : 0-20mA, 4-20mA, 0/1-5V, 0/2-10V
C : 0-60/75/100/150mV

type of outputs:
0 : no output
1 : REL
2 : OC

number of outputs:
0
1
2

Typical applications

1. Measuring and control in a closed tank according to set parameters, with acoustic alarm signalling, data transfer to the master system via an RS-485 interface.

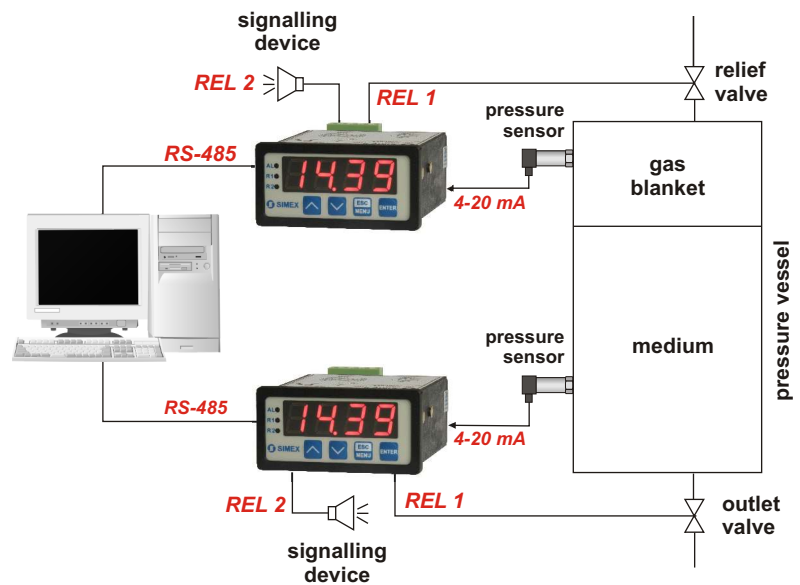

Technical data

- Power supply:** 19V + 50V DC; 16V + 35V AC or 85 + 260V AC/DC, all separated
- Power consumption:** for 85 + 260V AC/DC and 16V + 35V AC power supply: max. 4,5 VA; 19V + 50V DC power supply: max. 4,5 W
- Display:** LED, two-coloured (red-green), 4 x 13 mm (IP 40) - standard or LED, red, 5 x 9 mm (IP 65) - option
- Input:** current 0-20 mA or 4-20 mA, programmable, input resistance < 65 Ω (typ. 55 Ω), overload-protected, input current limited to 40 mA; voltage 0-5 V, 1-5V, 0-10V or 2-10V, programmable, input resistance > 50 kΩ; millivoltage 0-60 mV, 0-75 mV, 0-100 mV, 0-150 mV; programmable; input resistance > 100 kΩ
- Accepted prolonged input overload:** 20%
- Displayed values range:** -999 + 9999 + decimal point
- Accuracy:** 0.1% @25°C
- Stability:** 50 ppm/°C
- Outputs:** 0, 1 or 2 relays 1A/250V AC (cosφ=1) or the OC 30mA/30VDC/100mW
- Transducer power supply output:** 24V DC +5%, -10% / max. 100 mA, stabilized, not insulated from measuring inputs
- Communication interface:** RS-485, 8N1 and 8N2, 1200 bit/s + 115200 bit/s, Modbus RTU (not galvanically insulated from measuring inputs)
- Operating temperature:** 0°C + +50°C
- Storage temperature:** -10°C + +70°C
- Protection class (depending on display size):**
5 x 9 mm display: IP 65 (front), available additional frame IP 65 for panel cut-out sealing; IP 20 (case and connection clips)
4 x 13 mm display: IP 40 (front); IP 20 (case and connection clips)
- Case:** board
- Case material:** NORYL - GFN2S E1
- Case dimensions:** 72 x 36 x 97 mm
- Panel cut-out dimensions:** 66,5 x 32,5 mm
- Installation depth:** min. 102 mm
- Board thickness:** max. 5 mm