

SRP-147

- ▣ meter with a large 4 x 38 mm display
- ▣ measurement input 0/4-20 mA, 0/1-5V, 0/2-10V
- ▣ 0, 2 or 4 relay outputs (or OC)
- ▣ RS-485 / Modbus RTU
- ▣ option: active current output



The main advantage of the **SRP-147** meter is its large 38mm high LED display. The unit is equipped with measurement input: current 0/4-20 mA and voltage 0/1-5, 0/2-10V. The selection of active input type and range is realised by software. The device operates in the following modes: linear, root, square and user defined (max. 20 points). Optionally **SRP-147** with two relay outputs can be equipped with active current output. The 24V DC/100 mA output is used to power the measuring transducers. The RS-485 enables data transmission in production process monitoring systems. 2 or 4 relay (or OC) outputs make it possible to adjust the level of the measured signal. These outputs can be controlled according to one or two threshold values.

- programmable measuring range,
- programmable hystereses and delays of control outputs,
- programmable indication filtration,
- password for settings protection,
- 144 x 72 mm housing with readable display 4 x 38 mm,
- overload-protected current input.

Typical applications

1. Measuring methane concentration in a biogas plant, activating fan 1 when level I is exceeded, activating fan 2 when level II is exceeded.

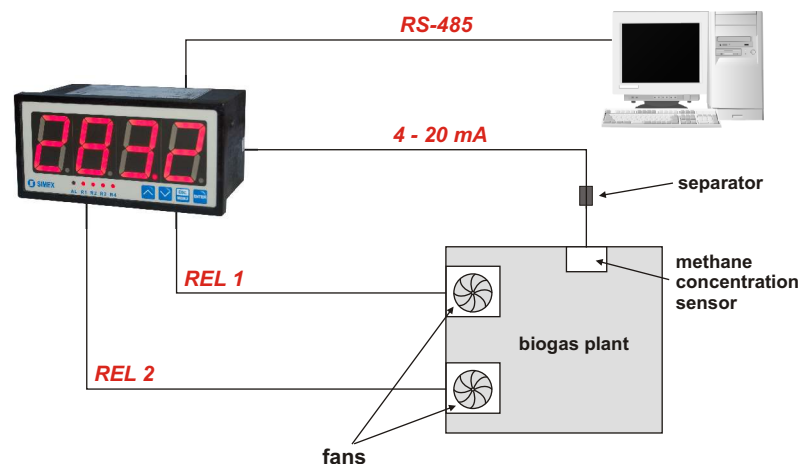

Exemplary pin assignment

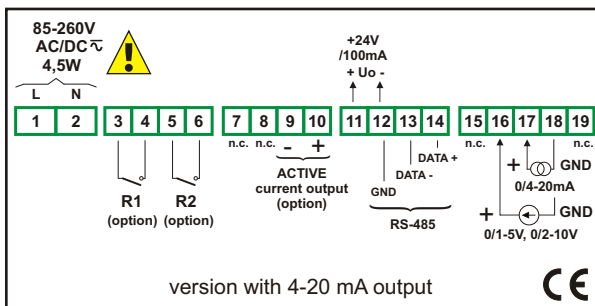

Technical data

- Power supply:** 19V + 50V DC; 16V + 35V AC or 85 + 260V AC/DC, all separated
- Power consumption:** for 85 + 260V AC/DC and 16V + 35V AC power supply: max. 4,5 VA; 19V + 50V DC power supply: max. 4,5 W
- Display:** LED, 4 x 38 mm high, red (green - on request)
- Input:** current 0-20 mA or 4-20 mA, programmable, input resistance < 65 Ω (typ. 55 Ω), overload-protected, input current limited to 40 mA;
voltage 0-5 V, 1-5V, 0-10V or 2-10V, programmable, input resistance > 50 kΩ
- Displayed values range:** -999 - 9999 + decimal point
- Accuracy:** 0.1% @25°C
- Stability:** 50 ppm/°C
- Outputs:** 0, 2 or 4; relays 1A/250V AC (cosφ=1) or the OC 30mA/30VDC/100mW
- Transducer power supply output:** 24V DC +5%, -10% / max. 100 mA, stabilized, not insulated from measuring inputs
- Active current output:** operating range max. 0/4 - 24 mA, load resistance max. 700 Ω (option available with 2 relays, see ordering)
- Communication interface:** RS-485, 8N1 and 8N2, 1200 bit/s + 115200 bit/s, Modbus RTU, not galvanically insulated from measuring inputs
- Operating temperature:** 0°C + 50°C
- Storage temperature:** -10°C + 70°C
- Protection class:** IP 65 (front), available additional frame IP 65 for panel cut-out sealing; IP 20 (case and connection clips)
- Case:** board
- Case material:** NORYL - GFN2S E1
- Case dimensions:** 144 x 72 x 100 mm
- Panel cut-out dimensions:** 138,5 x 67 mm
- Installation depth:** min. 102 mm
- Board thickness:** max. 5 mm

Ordering

