

IMPRESS

SENSORS & SYSTEMS

Unit 6 Mercury House, Calleva Park

Aldermaston, Berkshire, RG7 8PN

Tel: +44 (0)118 981 7980

Fax: +44 (0)118 981 7990

e-mail: sales@impress-sensors.co.uk

Website: www.impress-sensors.co.uk

Pressure - Temperature - Level - Distance - Control - Indication - Data logging



LMP 307

Stainless Steel Probe

Stainless Steel Sensor

accuracy according to IEC 60770:
Standard: 0.35 % FSO
Option: 0.25 % / 0.1 % FSO

Stainless Steel Probe

LMP 307

Nominal pressure

from 0 ... 1 mH₂O
up to 0 ... 250 mH₂O

Special characteristics

- ▶ diameter 27 mm
- ▶ small thermal effect
- ▶ excellent accuracy
- ▶ excellent long term stability

Optional versions

- ▶ IS-protection zone 0
- ▶ SIL 2 (Safety Integrity Level)
- ▶ cable protection via corrugated pipe
- ▶ different kinds of cables
- ▶ different kinds of elastomers

The stainless steel probe LMP 307 is designed for continuous level measurement in water and clean or waste fluids.

Basic element is a high quality stainless steel sensor with high requirements for exact measurement with excellent long term stability.

Preferred areas of use are

Water



drinking water system
ground water level measurement
rain spillway basin
pump and booster stations
level measurement in container

Sewage



water treatment plants
waste water treatment
water recycling

Fuel / Oil



fuel storage
tank farm



Visit the website: www.impress-sensors.co.uk

LMP 307

Stainless Steel Probe

Technical Data

Input pressure range													
Nominal pressure gauge [bar]	0.1	0.16	0.25	0.4	0.6	1	1.6	2.5	4	6	10	16	25
Level [mH ₂ O]	1	1.6	2.5	4	6	10	16	25	40	60	100	160	250
Overpressure [bar]	1	1	1	2	5	5	10	10	17.5	35	35	80	80
Burst pressure ≥ [bar]	1.5	1.5	1.5	3	7.5	7.5	15	15	25	50	50	120	120
Output signal / Supply													
Standard	2-wire: 4 ... 20 mA / V _s = 8 ... 32 V _{DC}												
Option Ex-protection	2-wire: 4 ... 20 mA / V _s = 10 ... 28 V _{DC}												
Options 3-wire	3-wire: 0 ... 20 mA / V _s = 14 ... 30 V _{DC} 0 ... 10 V / V _s = 14 ... 30 V _{DC}												
Performance													
Accuracy	standard: nominal pressure < 0.4 bar: ≤ ± 0.5 % FSO nominal pressure ≥ 0.4 bar: ≤ ± 0.35 % FSO option 1: nominal pressure ≥ 0.4 bar: ≤ ± 0.25 % FSO option 2: for all nominal pressures: ≤ ± 0.1 % FSO												
Permissible load	current 2-wire: R _{max} = [(V _s - V _s min) / 0.02] Ω current 3-wire: R _{max} = 500 Ω voltage 3-wire: R _{min} = 10 kΩ												
Influence effects	supply: 0.05 % FSO / 10 V load: 0.05 % FSO / kΩ												
Long term stability	≤ ± 0.1 % FSO / year												
Response time	2-wire: ≤ 10 msec 3-wire: ≤ 3 msec												
¹ accuracy according to IEC 60770 – limit point adjustment (non-linearity, hysteresis, repeatability)													
Thermal effects (Offset and Span)													
Nominal pressure P _N [bar]	< 0.40						≥ 0.40						
Tolerance band [% FSO]	≤ ± 1						≤ ± 0.75						
in compensated range [°C]	0 ... 70												
Permissible temperatures													
Permissible temperatures	medium: -10 ... 70 °C storage: -25 ... 70 °C												
Electrical protection ²													
Short-circuit protection	permanent												
Reverse polarity protection	no damage, but also no function												
Electromagnetic compatibility	emission and immunity according to EN 61326												
² additional external overvoltage protection unit in terminal box KL 1 or KL 2 with atmospheric pressure reference available on request													
Electrical connection													
Cable with sheath material ³	PVC	(-5 ... 70 °C)		grey									
	PUR	(-10 ... 70 °C)		black									
	FEP	(-10 ... 70 °C)		black									
³ cable with integrated air tube for atmospheric pressure reference													
Materials (media wetted)													
Housing	stainless steel 1.4404 (316L)												
Seals	FKM; others on request												
Diaphragm	stainless steel 1.4435 (316L)												
Protection cap	POM												
Explosion protection (only for 4 ... 20 mA / 2-wire)													
Approval DX19-LMP 307	IBExU10ATEX1068X zone 0: II 1 G Ex ia IIC T4 Ga zone 20: II 1 D Ex iaD 20 T85°C												
Safety technical maximum values	U _i = 28 V, I _i = 93 mA, P _i = 660 mW, C _i ≈ 0 nF, L _i ≈ 0 μH												
Permissible media temperature	in zone 0: -10 ... 60 °C with p _{atm} 0.8 bar up to 1.1 bar in zone 1 or higher: -10 ... 70 °C												
Connecting cables (by factory)	cable capacitance: signal line/shield also signal line/signal line: 160 pF/m cable inductance: signal line/shield also signal line/signal line: 1 μH/m												
Miscellaneous													
Option SIL 2 application	according to IEC 61508 / IEC 61511												
Current consumption	signal output current: max. 25 mA signal output voltage: max. 7 mA												
Weight	approx. 200 g (without cable)												
Ingress protection	IP 68												
CE-conformity	EMC Directive: 2004/108/EC												

Visit the website: www.impress-sensors.co.uk

LMP 307

Stainless Steel Probe

Technical Data

Wiring diagrams

2-wire-system (current)

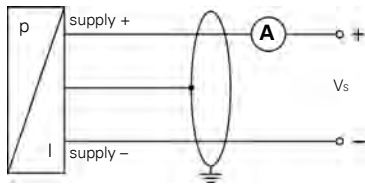

3-wire-system (current / voltage)

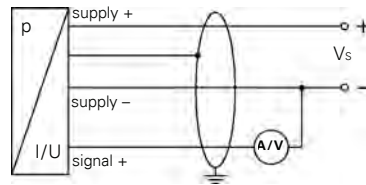

Pin configuration

Electrical connection	cable colours (DIN 47100)
Supply +	wh (white)
Supply -	bn (brown)
Signal + (only 3-wire)	gn (green)
Shield	gn/ye (green / yellow)

Dimensions (in mm)

standard

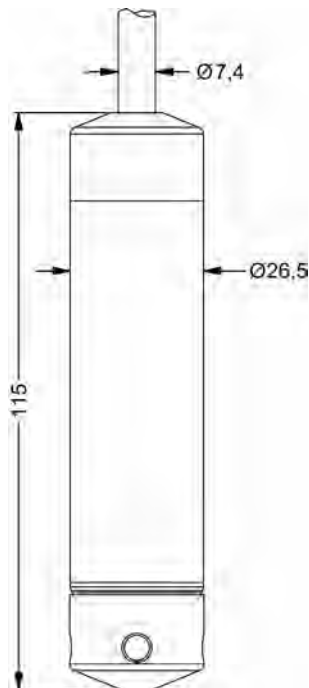

option

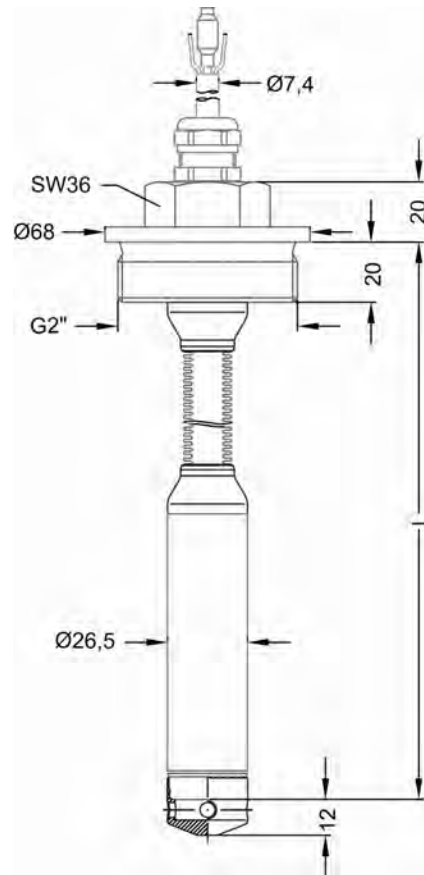

cable protection
with corrugated pipe

⇒ Total length of devices with accuracy 0.1 % FSO IEC 60770 increases by 35 mm!

Visit the website: www.impress-sensors.co.uk

Company Reg. No.: 4346738, VAT No.: 786 6596 54, Reg Address: Impress Sensors & Systems Ltd, Unit 6 Mercury House, Calleva Park, Aldermaston, Berkshire, RG7 8PN

LMP 307

Stainless Steel Probe

Accessories

Mounting flange with cable gland		
Technical data		
Suitable for	all probes	
Flange material	stainless steel 1.4404 (316L)	
Material of cable gland	standard: brass, nickel plated on request: stainless steel 1.4305 (303); plastic	
Seal insert	material: TPE (ingress protection IP 68)	
Hole pattern	according to DIN 2507	
Version	Size (in mm)	Weight
DN25 / PN40	D = 115, k = 85, b = 18, n = 4, d = 14	1.4 kg
DN50 / PN40	D = 165, k = 125, b = 20, n = 4, d = 18	3.2 kg
DN80 / PN16	D = 200, k = 160, b = 20, n = 8, d = 18	4.8 kg
Ordering type		Ordering code
DN25 / PN40 with cable gland brass, nickel plated		ZMF2540
DN50 / PN40 with cable gland brass, nickel plated		ZMF5040
DN80 / PN16 with cable gland brass, nickel plated		ZMF8016
cable gland M16x1.5 with seal insert (for cable-Ø 4 ... 11 mm)		
Terminal clamp		
Technical data		
Suitable for	all probes with cable Ø 5.5 ... 10.5 mm	
Material	standard: steel, zinc plated optionally: stainless steel 1.4301 (304)	
Weight	approx. 160 g	
Ordering type		Ordering code
Terminal clamp, steel, zinc plated		Z100528
Terminal clamp, stainless steel 1.4301 (304)		Z100527
Display program		
<p>CIT 200 Process display with LED display</p> <p>CIT 250 Process display with LED display and contacts</p> <p>CIT 300 Process display with LED display, contacts and analogue output</p> <p>CIT 350 Process display with LED display, bargraph, contacts and analogue output</p> <p>CIT 400 Process display with LED display, contacts, analogue output and Ex-approval</p> <p>CIT 600 Multichannel process display with graphics-capable LC display</p> <p>CIT 650 Multichannel process display with graphics-capable LC display and datalogger</p> <p>CIT 700 Multichannel process display with graphics-capable TFT monitor, touchscreen and contacts</p> <p>PA 440 Field display with 4-digit LC display</p>		

This data sheet contains product specification, properties are not guaranteed. Subject to change without notice.

Visit the website: www.impress-sensors.co.uk

Company Reg. No.: 4346738, VAT No.:786 6596 54, Reg Address: Impress Sensors & Systems Ltd, Unit 6 Mercury House, Calleva Park, Aldermaston, Berkshire, RG7 8PN