

The factory-set pressure switches in Ex zones.



Pressure switch 901..Ex

with factory-set pressure setting
for Ex zones 0, 1 and 2



Application

Factory-set pressure switch monitoring overpressure, vacuum or differential pressure of liquid and gaseous – also aggressive – media.

Pressure setting and switching differential are factory-set by the manufacturer.

Specifications

Medium	Air, (non-)combustible and aggressive gases and vapours
Temperature ranges: Medium and ambient temperature	-20° C to +85° C
Storage temperature	-40° C to +85° C
Trip pressure ranges: Overpressure	5 to 200 mbar (min. measuring range) 1 to 12 bar (max. measuring range)
Vacuum	-5 to -200 mbar (min. measuring range) -200 to -900 mbar (max. measuring range)
Differential pressure	5 to 50 mbar
Max. working overpressure	0.1 to 25 bar/-1 bar (refer to table)
Switching differential	2.5 to 1,500 mbar; depending on pressure range (refer to table)
Trip pressure tolerance	±10% from setpoint
Materials: Tube connection	5 / 6.5 and 10 mm, PA / PPS
Threaded connections	M10x1 / G1/8 to G1/2 PA/PVDF/stainless steel/brass
Diaphragm	depending on medium; NBR, silicone, FKM (Viton®), EPDM, for 901.30 silicone (other materials on request).
Weight	30 to 300 g (depending on housing material)
Electrical rating	24 VDC/100 mA; 30 VDC/45 mA
Electrical connection	AMP flat plug, 6.3 mm x 0.8 mm, in accordance with DIN 46244, or push-on screw terminals
Cable conduit	M16x1.5, with integrated cable strain relief
Protection category	IP 54 (with cover 6371)
Mechanical working life	over 10 ⁶ switching operations
Reducing nozzles	diameter optionally 0.3/0.5/0.8 mm

ATEX

EC type examination
Device category
Ignition protection type
CE conformity

BVS 06 ATEX E 141X
II 1/2G or II 2G
Ex ia IIB T4 or Ex ia IIC T4
ATEX Directive 94/9/EC
RoHS-Directive 2002/95/EC

Other approvals

type examination by
TUV Südwest and DVGW

Ex i-circuits

This pressure switch can be used in potentially explosive zones 0, 1 and 2. In the safe area, an associated isolating means (separating barrier, switching amplifier) must be connected before. The entire isolating circuit must then be proved to keep inherent safety.

For this purpose, the power specifications (P, I, U) of the barrier must be lower and the characteristics (L, C) higher than those of the pressure switch and of the connection line (blue colour).

Characteristics for IIB, C:

Voltage	- Ui	24 VDC/30 VDC
Current	- Ii	100 mA/45 mA
Capacitance	- Ci	0 µF
Inductance	- Li	0 mH

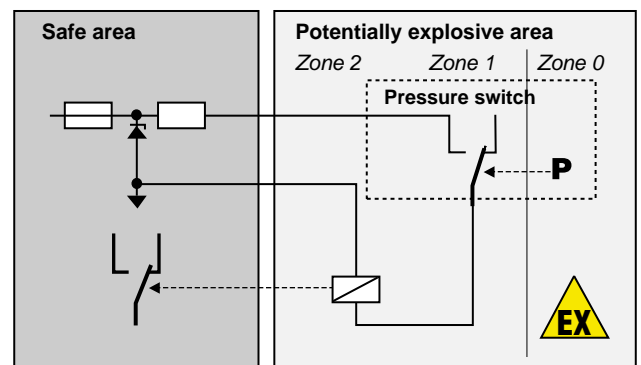

Arrangement of contacts

for 901.1x Ex, 901.30 Ex,
901.41 Ex, 901.51 Ex

only for 901.2x Ex

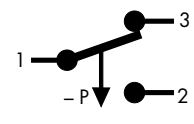
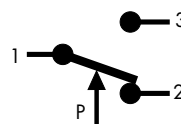

Pressure connections

Type	Tube connections			Threaded connections			
	5.0 mm	6.5 mm	10.0 mm	M10 x1	G1/8	G1/4	G 1/2
901.1x Ex	PA	PA, PPS	PA, PPS	PA, PVDF, MS, V ₂ A	PA, PVDF, MS, V ₂ A	PVDF MS, V ₂ A	MS
901.2x Ex	PA	PA, PPS	PA, PPS	PA, PVDF, MS, V ₂ A	PA, PVDF MS, V ₂ A	MS, V ₂ A	MS
901.30 Ex		PA					
901.41 Ex		PA, PPS	PA, PPS	PA, PVDF, MS, V ₂ A	PA, PVDF, MS, V ₂ A	MS, V ₂ A	MS
901.51 Ex				MS	MS, V ₂ A	MS, V ₂ A	

PA = polyamide, PVDF = polyvinylidene fluoride, PPS = polyphenylsulfide, MS = brass

Overpressure ranges

Type	Factory-set trip pressure selectable		Standard switching differential		Tolerance band in % of trip pressure	Maximum positive working pressure	Maximum negative working pressure
	between	and	lower end of range	upper end of range			
901.1x Ex	5	200 mbar	2.5 mbar	50 mbar	±10%	0.5/4 bar	-/-1 bar
	200	1,000 mbar	50 mbar	150 mbar	±10%	1/4 bar	-/-1 bar
901.41 Ex	500	3,000 mbar	200 mbar	600 mbar	±10%	10 bar	-1 bar
901.51 Ex	1.0	12 bar	0.2 bar	1.5 bar	±10%	25 bar	-1 bar

Vacuum ranges

Type	Factory-set trip pressure selectable		Standard switching differential		Tolerance band in % of trip pressure	Maximum positive working pressure	Maximum negative working pressure
	between	and	lower end of range	upper end of range			
901.2x Ex	-5	-200 mbar	2.5 mbar	50 mbar	±10%	0,5/4 bar	-1 bar
	-200	-900 mbar	50 mbar	150 mbar	±10%	1/4 bar	-1 bar

Differential pressure ranges

Type	Factory-set trip pressure selectable		Standard switching differential		Tolerance band in % of trip pressure	Maximum positive working pressure	Maximum negative working pressure
	between	and	lower end of range	upper end of range			
901.30 Ex	5	50 mbar	2.5 mbar	25 mbar	±10%	100 mbar	-100 mbar

Pressure switch 901..Ex

with factory-set pressure setting for Ex zones 0,1 and 2



901.10/20

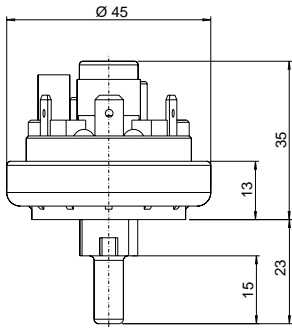

901.30

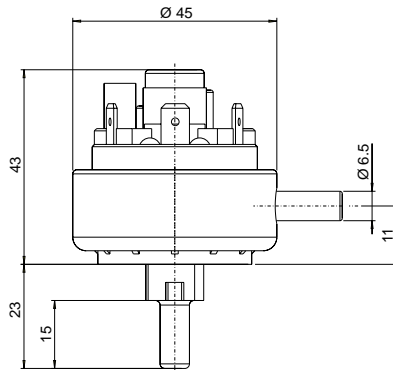

**Covers
6371 IP 54 / 6372 IP 65**

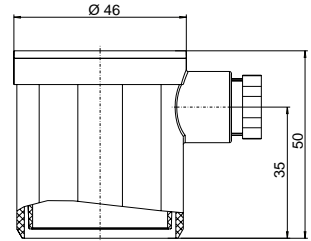

901.11/21/41

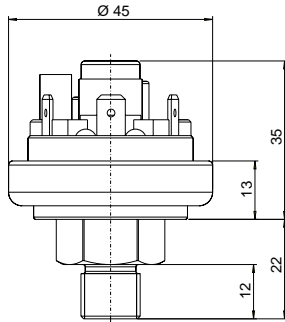

901.51

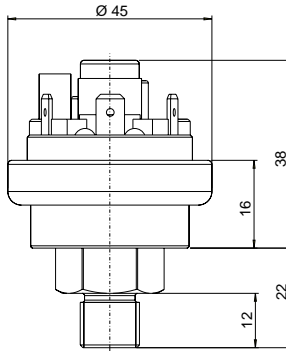

6374 IP 54 / 6375 IP 65

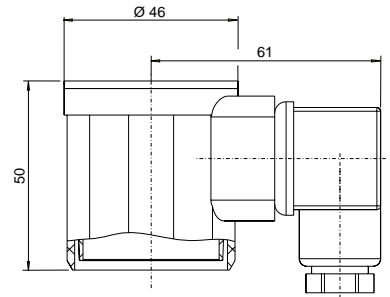

Mounting brackets

6403

6404

6405

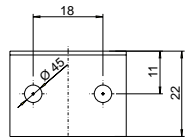
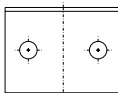
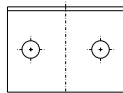
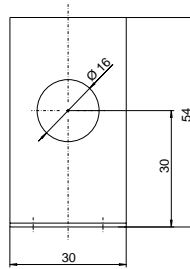
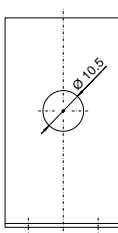
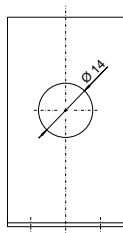
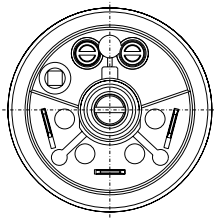

Technical data subject to change without prior notice.

901_ex_data_english 1/09

QUALITY MANAGEMENT
Certificate
Voluntary participation in regular monitoring according to ISO 9001:2000



Viton® is a registered trademark of DuPont Dow Elastomers.

Visit the website: www.impress-sensors.co.uk

Company Reg. No.: 4346738, VAT No.: 786 6596 54, Reg Address: IMPress Sensors & Systems Ltd, Unit 6B, Mercury House, Calleva Park, Aldermaston, Berkshire, RG7 8PN