

IMPRESS

SENSORS & SYSTEMS

Unit 6B, Mercury House, Calleva Park
Aldermaston, Berkshire, RG7 8PN

Tel: +44 (0)118 981 7980

Fax: +44 (0)118 981 7990

e-mail: info@impress-sensors.co.uk

Website: www.impress-sensors.co.uk

Pressure - Temperature - Level - Flow - Analytical - Control - Indication - Data logging

The adjustable pressure switches Prescal®.



Visit the website: www.impress-sensors.co.uk

Company Reg. No.: 4346738, VAT No.: 786 6596 54, Reg Address: IMPress Sensors & Systems Ltd, Unit 6B, Mercury House, Calleva Park, Aldermaston, Berkshire, RG7 8PN

Pressure switch 901 Prescal®

with adjustable setting

Application

Adjustable pressure switch monitoring overpressure, vacuum or differential pressure of liquid and gaseous – also aggressive – media.

The pressure switch uses a scaled adjustment knob to enable the adjustment of trip and reset pressure without the use of a screwdriver.

Temperature range

Ambient temperature from -20°C to 85°C .
Temperature of media from 85°C or 130°C depending on material of pressure connection and diaphragm.

Diaphragm material

Depending on media NBR, Silicone, FKM (Viton®), EPDM.
For 901.8x Silicone, others upon request.

Electrical rating

Values indicated for resistive load

AgCdO-contacts: 6 (1.5) A/250 VAC
2 A/24 VDC
Gold-plated contacts: 100 mA/24 VAC
30 mA/24 VDC

Electrical connection

AMP connection 6.3 mm x 0.8 mm DIN 46244.

Arrangement of contacts

for 901.6x, 901.8x,
901.9x

only for 901.7x

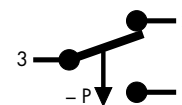
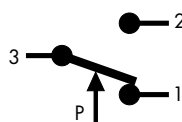

Approvals

CE conformance according to EC Low Voltage Directive 73/23/EEC. For Type 901.61 to 901.65 with brass pressure connection CE conformance according to EC Gas Appliance Directive 90/396/EEC.

Life

Minimum 10^6 cycles.

Damping

Restrictors alternatively with 0.3/0.5/0.8 mm diameter.

Accessories

Various mounting brackets and protection caps with IP 44, IP 54 and IP 65.

Mounting position

Mounting in any position, to be specified for settings below 100 mbar.

Pressure connection

Type	Tube connection			Threaded connection					
	5.0 mm FS	6.5 mm FS	10.0 mm FS	M 10 x1	G 1/8	M 10 x1	G 1/8	G 1/4	G 1/2
901.61–65	PA	PA PPS	PA PPS	PA PVDF	PA PVDF	CuZn40 V ₂ A	CuZn40 V ₂ A	CuZn40 V ₂ A	CuZn40
901.66–68						CuZn40 V ₂ A	CuZn40 V ₂ A	CuZn40 V ₂ A	CuZn40
901.71–76	PA	PA PPS	PA PPS	PA PVDF	PA PVDF	CuZn40 V ₂ A	CuZn40 V ₂ A	CuZn40 V ₂ A	
901.77–78						CuZn40 V ₂ A	CuZn40 V ₂ A	CuZn40 V ₂ A	CuZn40
901.8x		PA							
901.91–93						CuZn40	CuZn40 V ₂ A	CuZn40 V ₂ A	

PA = polyamide, PVDF = polyvinylidene fluoride, PPS = polyphenylsulfide, CuZn40 = brass, FS = fastening spring

For temperature above 85°C brass, PVDF or PPS pressure connection is required. Upon request pressure connections of other sizes, other plastics or stainless steel are available.

Viton® is a registered trademark of DuPont Dow Elastomers.

Visit the website: www.impress-sensors.co.uk



Overpressure range

Type	Adjustment range for trip pressure		Tolerance band in % of	Switching differential	Maximum positive working pressure	
	from	to			standard/extended	standard/extended
901.61	5	20 mbar	± 10 %	3 mbar	0.5/4 bar	-/-1 bar
901.62	10	50 mbar	± 10 %	5 mbar	0.5/4 bar	-/-1 bar
901.63	25	100 mbar	± 10 %	10 mbar	0.5/4 bar	-/-1 bar
901.64	50	250 mbar	± 10 %	20 mbar	1/4 bar	-/-1 bar
901.65	100	500 mbar	± 10 %	50 mbar	1/4 bar	-/-1 bar
901.66	250	1.000 mbar	± 10 %	150 mbar	10 bar	-1 bar
901.67	500	1.500 mbar	± 10 %	250 mbar	10 bar	-1 bar
901.68	1.000	3.000 mbar	± 10 %	500 mbar	10 bar	-1 bar
901.91	1.0	6.0 bar	± 10 %	0.5 – 2.0 bar	25 bar	-1 bar
901.92	4.0	9.0 bar	± 10 %	0.5 – 2.0 bar	25 bar	-1 bar
901.93	7.0	12.0 bar	± 10 %	0.5 – 2.0 bar	25 bar	-1 bar

Vacuum range

901.71	- 5	- 20 mbar	± 10 %	3 mbar	0.5/4 bar	-1 bar
901.72	- 10	- 50 mbar	± 10 %	5 mbar	0.5/4 bar	-1 bar
901.73	- 25	- 100 mbar	± 10 %	10 mbar	0.5/4 bar	-1 bar
901.74	- 50	- 125 mbar	± 10 %	20 mbar	0.5/4 bar	-1 bar
901.75	- 75	- 200 mbar	± 10 %	25 mbar	1/4 bar	-1 bar
901.76	- 100	- 300 mbar	± 10 %	30 mbar	1/4 bar	-1 bar
901.77	- 200	- 500 mbar	± 10 %	75 mbar	1/4 bar	-1 bar
901.78	- 300	- 700 mbar	± 10 %	75 mbar	1/4 bar	-1 bar

Differential pressure range

901.81	5	20 mbar	± 10 %	3 mbar	100 mbar	-100 mbar
901.82	10	50 mbar	± 10 %	5 mbar	100 mbar	-100 mbar

Visit the website: www.impress-sensors.co.uk

Pressure switch 901 Prescal®

with adjustable setting

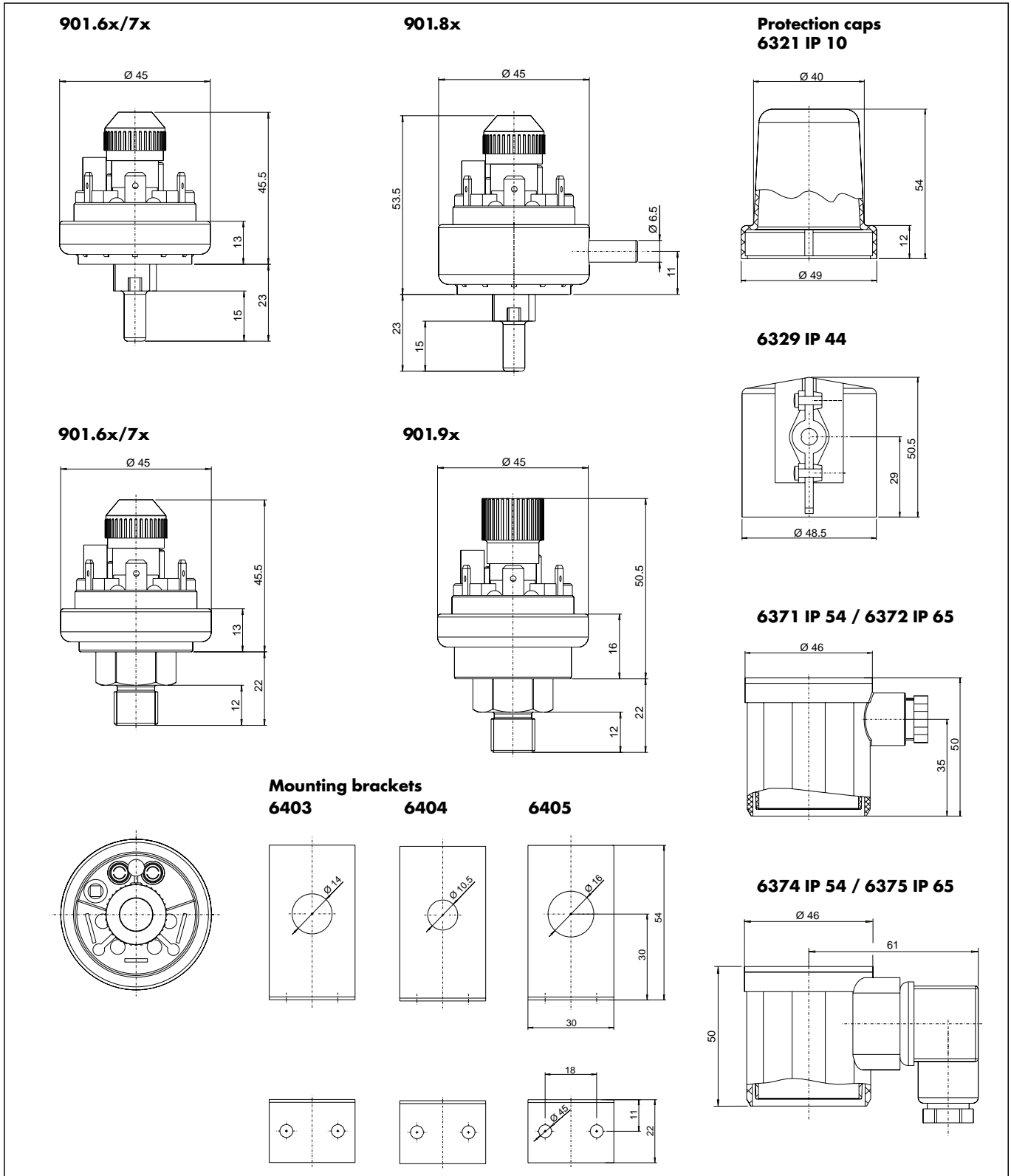

Visit the website: www.impress-sensors.co.uk

Company Reg. No.: 4346738, VAT No.: 786 6596 54, Reg Address: IMPress Sensors & Systems Ltd, Unit 6B, Mercury House, Calleva Park, Aldermaston, Berkshire, RG7 8PN